



DS211

## DOLPHIN UP & OVER COUNTER MOUNTED INFORM TAP

---

### INSTALLATION AND MAINTENANCE GUIDE

DS211.150.150 > 150 Height x 150 Length

DS211.200.200 > 200 Height x 200 Length

## DS21 I

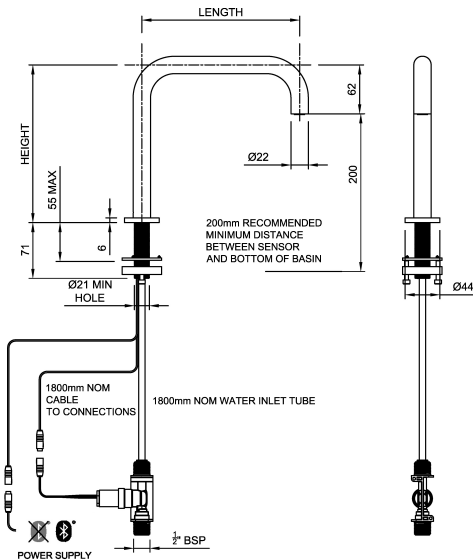

### TECHNICAL DATA

- › Dolphin Up and Over Counter Mounted InForm (SMART) Tap
- › Manufactured from high-quality, highly durable 1.4401 (316) Marine grade stainless steel.
- › Self-Monitoring Analysis and Recording Technology (SMART) allows the Facilities Manager to connect point to point via the Dolphin SMART App when used with the optional Bluetooth Adaptor (Sold separately -Order product code 25148 )
- › Infra-Red Touch Free Tap for ultimate hygiene prevents cross contamination Sensor mounted in end of spout
- › Flow rate – 3.0 litres/minute with the standard fitted flow regulator (fitted adjacent to solenoid) at any pressure between 0.5 and 6.0 bar
- › 1.0 - 4.0 litres/minute flow rates available to special order – please enquire
- › Water Supply: Single inlet cold or pre-mixed a TMV2 or TMV3 thermostatic mixing valve is recommended for premixed applications
- › Maximum operating water temperature - 60°C
- › Power Supply: \*
- › Nominal Current: Less than 1mA (Less than 25mA with Bluetooth)
- › Nominal Power: Less than 1W
- › Security Time can be adjusted via the App Default 20 Seconds (60 Seconds max)
- › IP68 Connector

#### Coding Explained

##### Style

DS21 I 90° Bent Spout  
DS21X.XXX..XXX.X

##### Projection

200mm DS21X.XXX.XXX.X

##### Height

200mm DS21X.XXX.XXX.X

##### Finish

1 Brushed Satin  
2 Mirror Polished  
3 PVD Brushed  
4 PVD Mirror  
5 Powder Coated  
DS21X.XXX.XXX.0

##### Colour

Suffix to end of code  
(Number allocated by Dolphin Solutions)

##### Example Coding

DS21 I .200.200.1  
90° Bent Spout  
200mm Projection  
200mm Height  
Brushed Satin Finish

##### Options

Bluetooth   
PVD  
Powder Coating

\* See page 4 for power supply and other options

## PACK CONTENTS

- 1 Solenoid Adaptor Housing
- 2 Solenoid
- 3 Washer Flow Regulator
- 4 Flow Regulator Housing
- 5 1/2 Cartridge
- 6 8mm Tube
- 7 Tail
- 8 Screw M6x20 Cap Head
- 9 M18 Knurled Lock Nut
- 10 M3x6 Grub Screw
- 11 Lock Washer (Large)
- 11 Lock Washer (Small)
- 12 Oring
- 13 Rosette
- 14 M4x3 Grub Screw
- 15 M4x4 Grub Screw
- 16 Body
- 17 Mesh
- 18 Nozzle
- 19 ORing
- 20 Sensor Assembly
- 21 Nozzle Housing

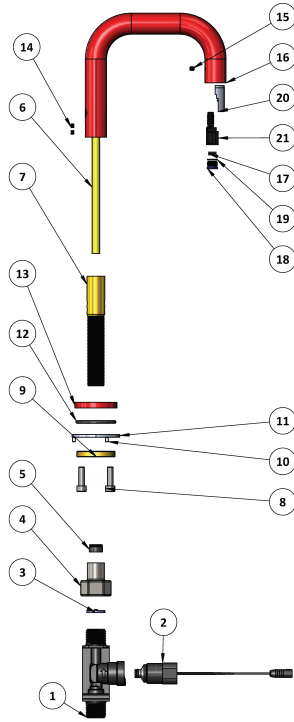

### Options



Standard ✓ ? Order 25148 separately



Bar  
0.5 min  
6.0 max

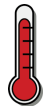

°C  
60 ✓



3L/min

## PRE INSTALLATION

› Please check that all the components in the list above are present and that they are in good condition before installation. If any components are missing contact Dolphin Solutions.

› It is very important to allow permanent access to the mounting tail/nut of this product for future servicing and repair. Where this is not possible see our wall plate mounted products.

### ⚠ WARNING

› Highly reflective surfaces directly beneath the sensor of this product, in particular polished finish basin wastes/strainers, will cause false activation of the infrared sensors and can result in malfunction. We recommend Satin or Matt finish products which can be found on our website.

› Sitting water may also cause the tap to activate

› All Plumbing and Electrical installation must be carried out by a qualified person and in accordance with applicable codes and regulations.

› Do not kink the water supply hose.

## INSTALLATION

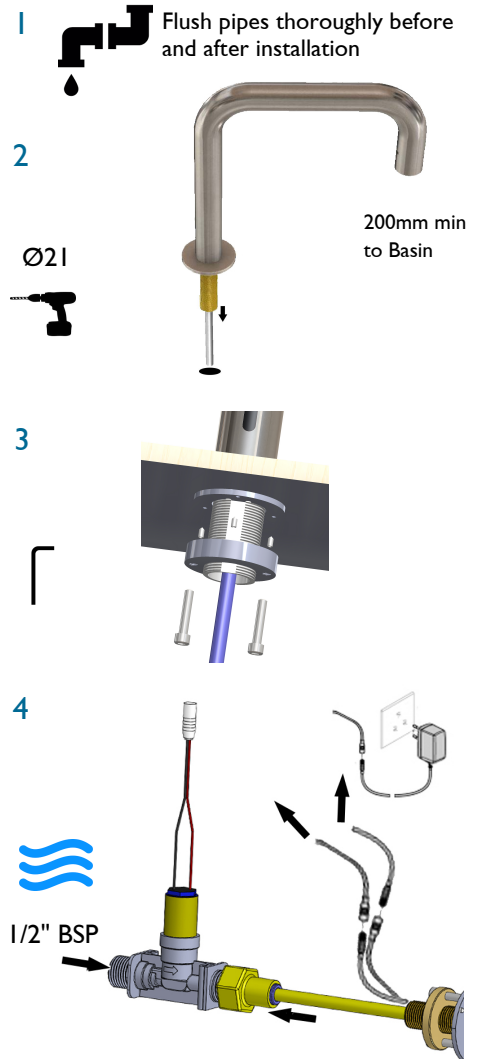

5 › Switch on power supply

› The sensor is self adjusting.\*

\*Further adjustments can be made by purchasing the Bluetooth Adaptor and downloading the App

6 Open hot and cold water supply and check that connections are watertight.

## MAINTENANCE

**DO NOT** use steel wool or cleansing agents containing alcohol, acid, abrasives or the like. Use of any prohibited cleaning or maintenance products or substances could damage the surface of the tap. For surface cleaning of tap use **ONLY** soap and water then wipe dry with a clean soft cloth. Protect taps from splattering of harsh cleansers when cleaning surroundings.

## OPTIONS

### POWER SUPPLY OPTIONS

**UK MAINS ADPATOR PRODUCT CODE 25147**  
(Other Adaptor pin and power supply configurations available, see below for part numbers):

- › Input voltage: 100 – 240V AC +/- 10%, 50 - 60 Hz
  - › Output voltage: 6.75V DC + 0.15V/ -0.35 V
  - › Secondary current: 0 - 350 mA DC
  - › Buffer capacitors: The adaptor secondary contains 3 buffer capacitors (necessary to close the solenoid valve in case of power outage):
    - 2 x 2200 µF,
    - 1 x 100µF
- Certifications: EN 60335-1, EN 60950-1
- › 1m Cable

**HARDWIRE TRANSFORMER PRODUCT CODE 25240**

- › Input voltage: 100 – 240V ± 10% 50-60 Hz ± 3 Hz
  - › Output voltage: 6.6V DC ± 5%
  - › Secondary current: 200 mA DC
  - › Buffer capacitors: one buffer capacitor 4700 µF (necessary to close the solenoid valve in case of power outage)
- Certifications: EN 60335-1, EN 61558-2
- › 1m Cable (Transformer to Tap), 2m Cable (Transformer to Mains)

**BATTERY PACK PRODUCT CODE 25241**

- › Requires a 6V lithium battery (CR-P2, approx. 1.500mAh) which has a lifetime of 200.000 switching cycles or 3-5 years depending on user frequency.
- › 100mm Cable (Approx)
- › **Important note** - the battery unit can't be used in combination with the Bluetooth adaptor.

The battery unit contains the CR-P2 battery as delivery content. The housing enables a fixation on wall by using the mounting clips (part of the housing but screws are not included) or the rear affixed Velcro tape

Power Supply Options:  
25147 UK Mains Adaptor  
25428 EURO Mains Adaptor  
25240 Hardwire Transformer  
25241 Battery Pack

### BLUETOOTH ADAPTOR PRODUCT CODE 25148



Bluetooth® version 4.0.

The **current version** of the app required for using the system **must** be installed on the control unit in advance. The App is available for free in the iTunes Store (requires an Apple account) and the Google Play store (requires a Google account).

For operation under adverse environments, in buildings / rooms with reinforced concrete walls, steel and iron frame, or near of obstructions (eg furniture) of metal, the Bluetooth reception can be disturbed and interrupted.

#### **Bluetooth®:**

Power consumption:	Less than 25mA
Output:	Bluetooth® - Class 2
Bluetooth® - version:	4.0
Bluetooth® - Transmission distance: (depending on the environments)	about 10m
Automatic safety shut-off:(10/20/60 seconds - adjustable)	20 s
Run-on time (0 - 10 s adjustable):	1 s
Detection Range - Levels 1 to 10 (10 = 120mm approx)	10